

KENWOOD

ELECTRONIC CROSSOVER NETWORK

KEC-301

---

## INSTRUCTION MANUAL

KENWOOD CORPORATION

**Take the time to read through this instruction manual. Familiarity with installation and operation procedures will help you obtain the best performance from your new electronic crossover network.**

### **For your records**

Record the serial number found on the bottom of the unit in the spaces designated on the warranty card and in the space provided below. Refer to the model and serial numbers whenever you call upon your KENWOOD dealer for information or service on this product.

Model KEC-301 Serial number \_\_\_\_\_

# **WARNING**

TO PREVENT ELECTRIC SHOCK,  
FIRE AND OTHER INJURY.  
PLEASE NOTE THE FOLLOWINGS:

- The unit is designed to be connected 12 V DC and negative grounding.

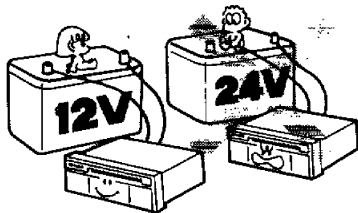

- Do not place the unit, where it will be exposed to direct sunlight or close to heating device.

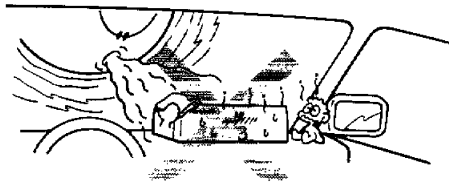

- Do not open enclosure, such as front panel, top or bottom cover.

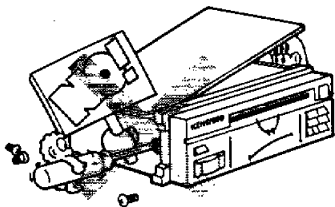

- Do not dash water on the unit.

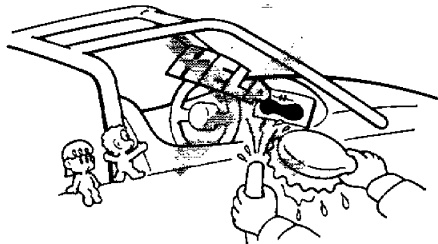

- Do not drop pieces of metal, needles, coins and other electrically conductive materials into the unit.

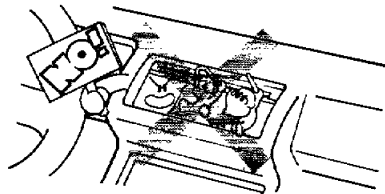

- Do not place the unit in areas of excessive dust, high humidity or on unstable surfaces.

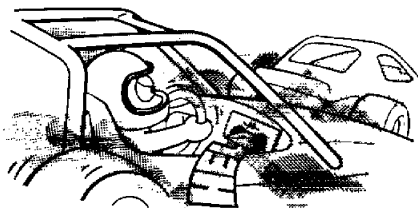

## CLEANING

1. Turn the power off, before cleaning the unit.
2. Do not use any type of abrasive pad, thinner, benzine and any such kind of objects.
3. Wipe the front panel and other exterior surfaces of the unit with a soft dry cloth or a soft cloth lightly moistened with a neutral detergent.

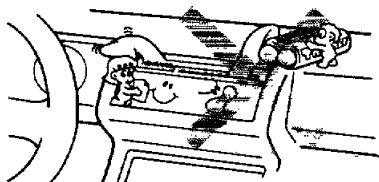

- If an abnormal smell or smoke is detected, immediately turn the power off.



- If you have difficulty in installing the set in your car, please contact your KENWOOD dealer.

# SWITCH SETTINGS ACCORDING TO SPEAKER SYSTEM

- Set the middle frequency switches for the rear speakers according to the type of system.

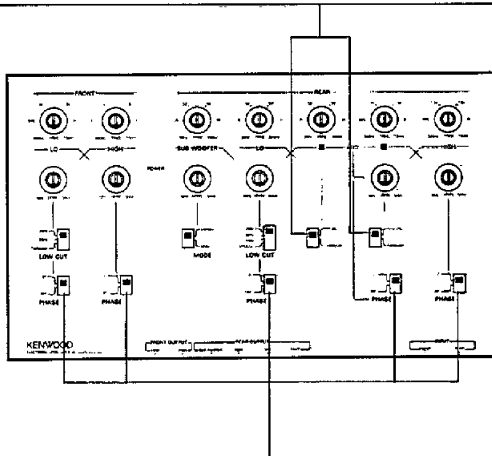
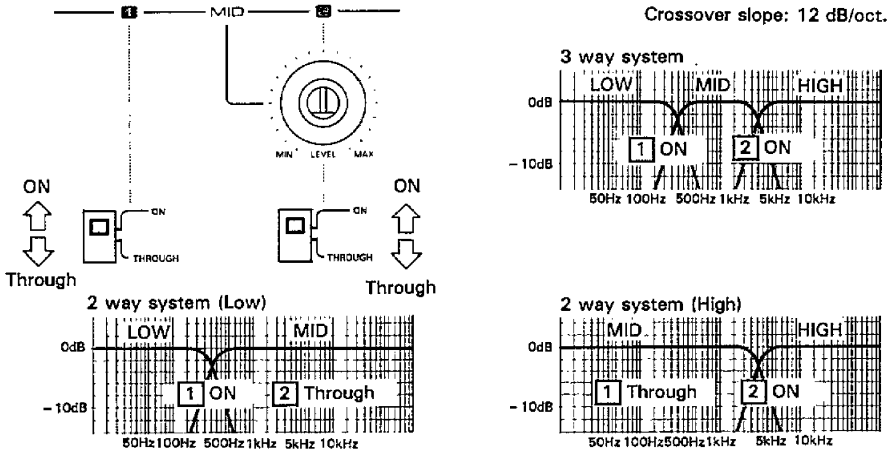

- The phase of each frequency band can be reversed by 180°.

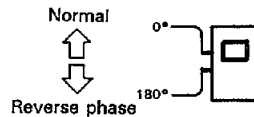

# REAR-FRONT HIGH FREQUENCY ADJUST

When this knob is used to adjust the high-pass cut-off frequency, the high-pass cut-off frequency can be adjusted from 800 Hz to 10 kHz according to the high frequency characteristics of the speaker.

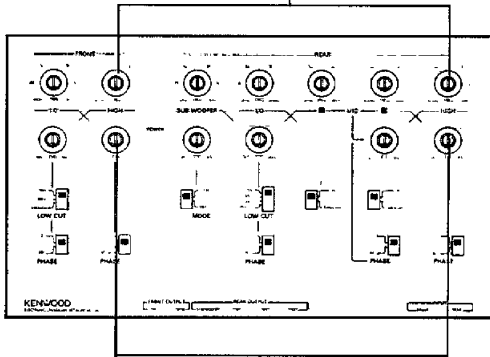
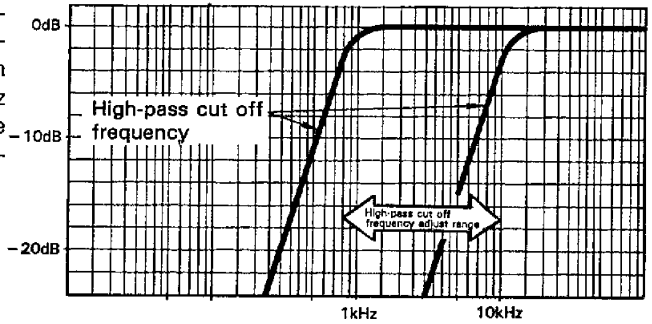
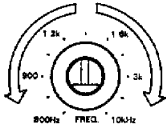

When this knob is used to adjust the high output level, the high output level can be adjusted from minus infinity (MIN) to 0 dB (MAX) according to the amplifier output power and speaker capacity.

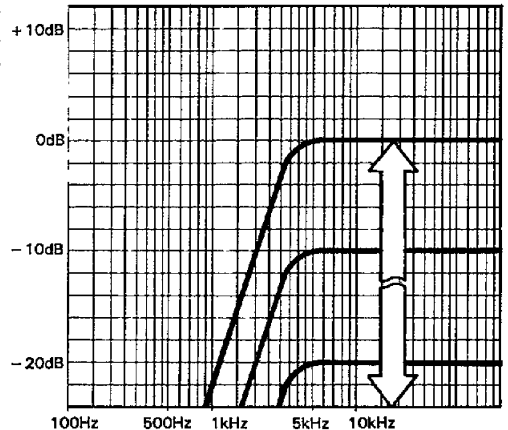
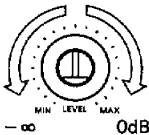

# REAR MIDDLE FREQUENCY ADJUST

When this knob is used to adjust the band-pass cut-off frequency, the band-pass cut-off frequency can be adjusted from 30 Hz to 800 Hz according to the low frequency characteristics of the speaker.

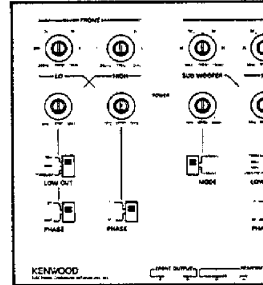
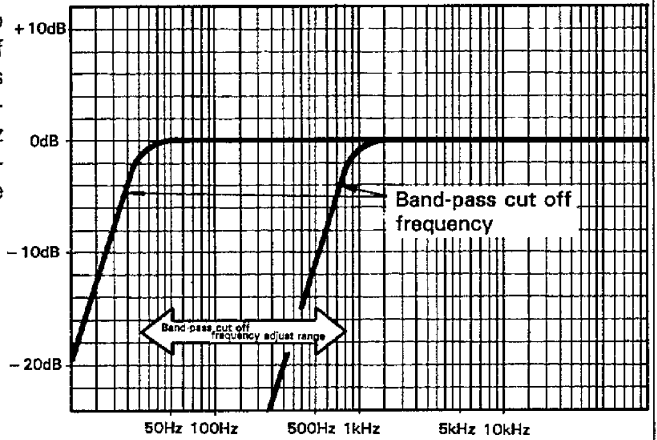
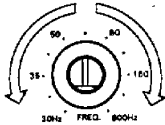

When this knob is used to adjust the middle output level, the middle output level can be adjusted from minus infinity (MIN) to 0 dB (MAX) according to the amplifier output power and speaker capacity.

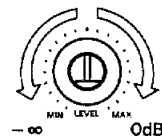

When this knob is used to adjust the band-pass cut-off frequency, the band-pass cut-off frequency can be adjusted from 800 Hz to 10 kHz according to the high frequency characteristics of the speaker.

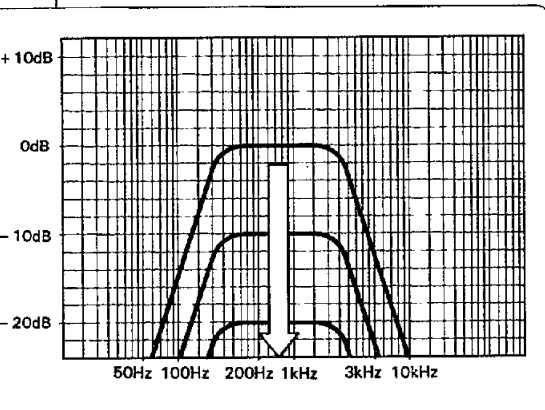
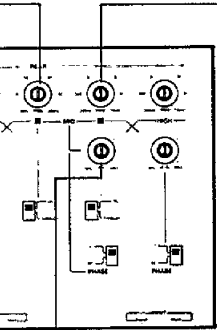
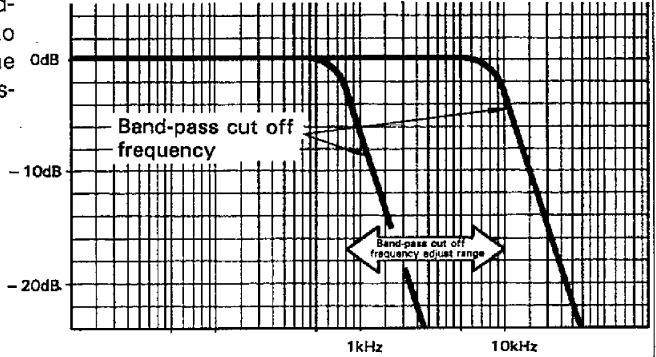
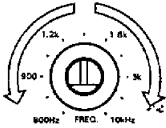

# REAR LOW FREQUENCY ADJUST

When this knob is used to adjust the low-pass cut-off frequency, the low-pass cut-off frequency can be adjusted from 30 Hz to 800 Hz according to the low frequency characteristics of the speaker.

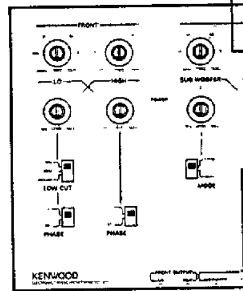
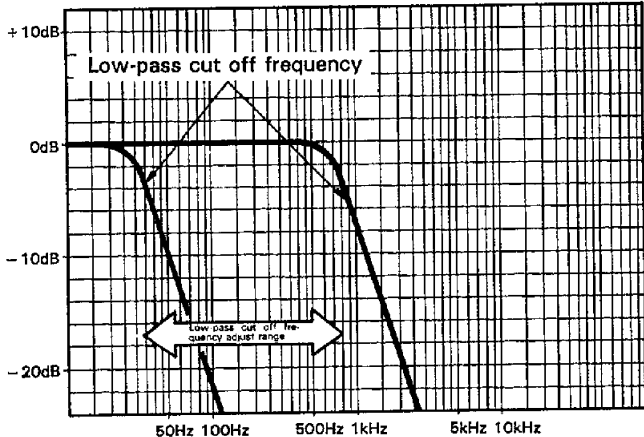
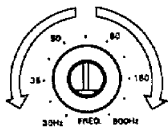

When a sub-woofer is set, use the low cut off switch to select 120 Hz, 80 Hz, or 50 Hz as the low cut off frequency.

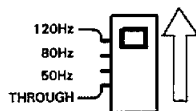



When this knob is used to adjust the low output level, the low output level can be adjusted from minus infinity (MIN) to 0 dB (MAX) according to the amplifier output power and speaker capacity.

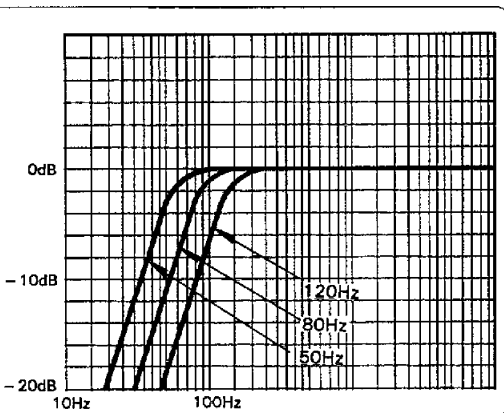
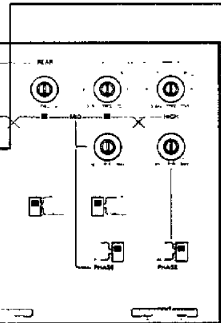
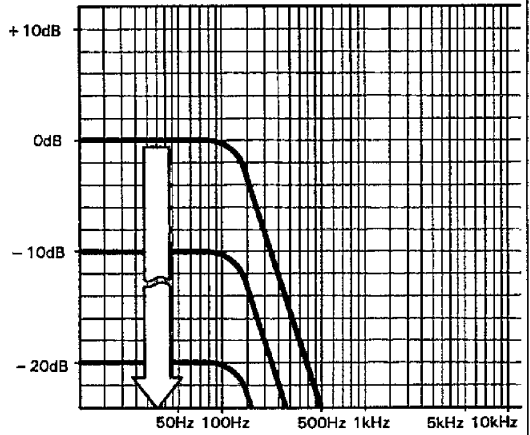
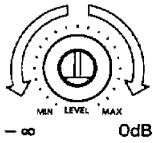

# FRONT LOW FREQUENCY ADJUST

When this knob is used to adjust the low-pass cut-off frequency, the low-pass cut-off frequency can be adjusted from 800 Hz to 10 kHz according to the low frequency characteristics of the speaker.

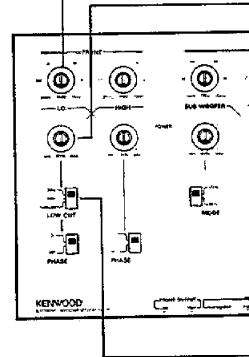
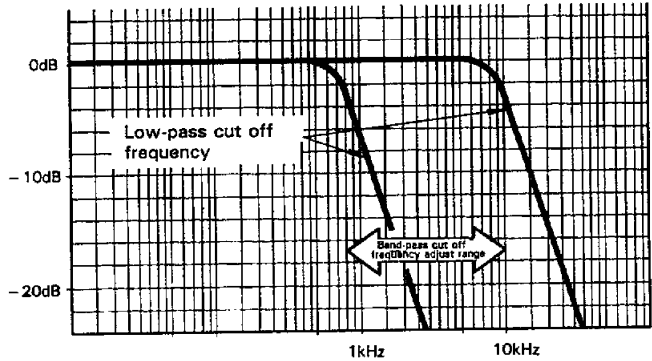
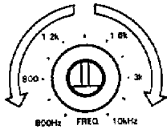

When a sub-woofer is set, use the low cut off switch to select 120 Hz or 80 Hz as the low cut off frequency.

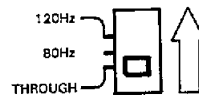

When this knob is used to adjust the low output level, the low output level can be adjusted from minus infinity (MIN) to 0 dB (MAX) according to the amplifier output power and speaker capacity.

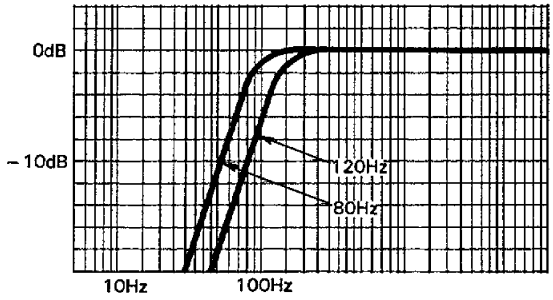
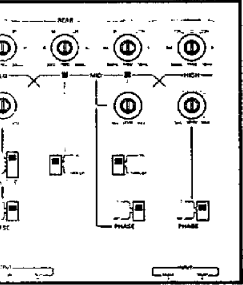
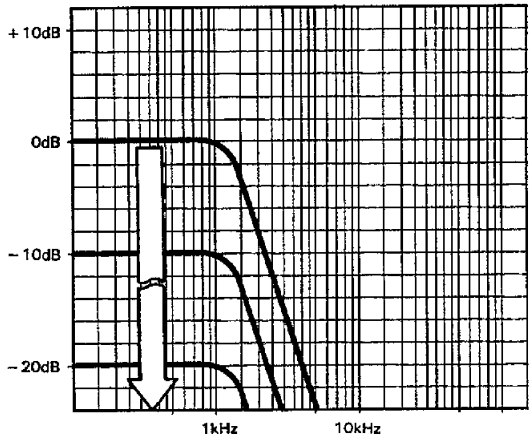
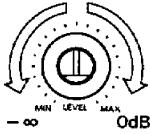

# SUB-WOOFER ADJUST

When this knob is used to adjust the sub-woofer cut-off frequency, the sub-woofer cut-off frequency can be adjusted from 30 Hz to 150 Hz according to the sub-woofer characteristics of the speaker.

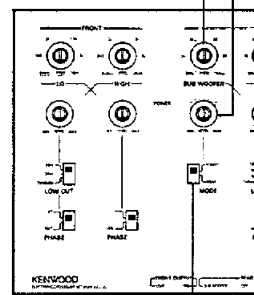
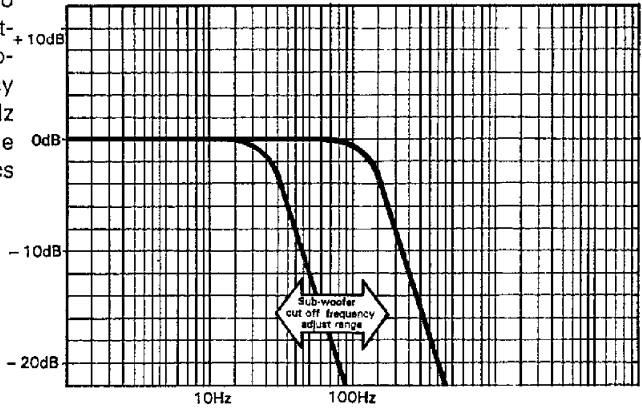
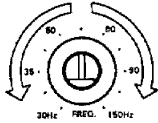

The "stereo" feeling is not perceived to a great extent with low frequency sounds. Also, if stereo sounds are present in the low frequency range, the signals from the left and right channels interfere with each other.

With this switch, the sub-woofer sound can be set to monaural. When the switch is set to monaural, the crossover slope changes from 12 dB/octave (stereo) to 18 dB/octave (monaural).

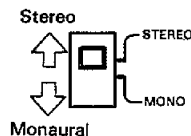

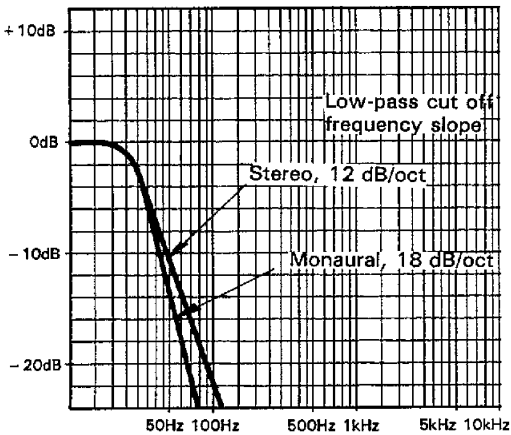
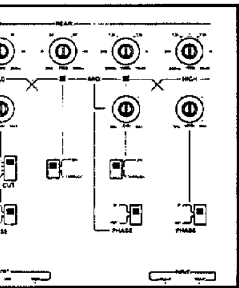
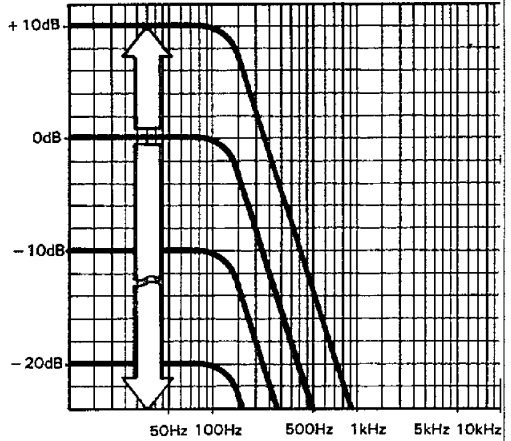
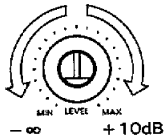

When this knob is used to adjust the sub-woofer output level, the sub-woofer output level can be adjusted from minus infinity (MIN) to +10 dB (MAX) according to the amplifier output power and speaker capacity.

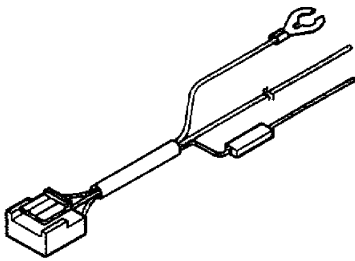
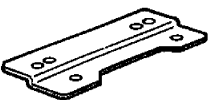

# ACCESSORY AND INSTALL MANNER

## ■ ACCESSORY

No.	Part name	External View	Number of units
①	Power connection cord		1
②	Metal fixture		2
③	Pan head screws (M3 × 5)		4
④	Tapping screws (φ4 × 14)		4

## ■ INSTALL MANNER

1. Before installation and wiring, remove the (-) terminal of the battery to prevent short-circuiting.
2. Connect the input and output cords of the system.
3. Connect the ground to the metal chassis of the car.
4. Connect the back-up power supply lead (yellow).
5. Install the set and after confirming the installation and wirings are correct, connect the (-) terminal of the battery.



If a fuse is blown, first check that the associated wires are not short-circuited then replace the fuse with a new one having the same capacity.

# INSTALLATION

■ When installing to the car, install the unit securely for safety driving.

- Use screws supplied as accessories when installing the unit.

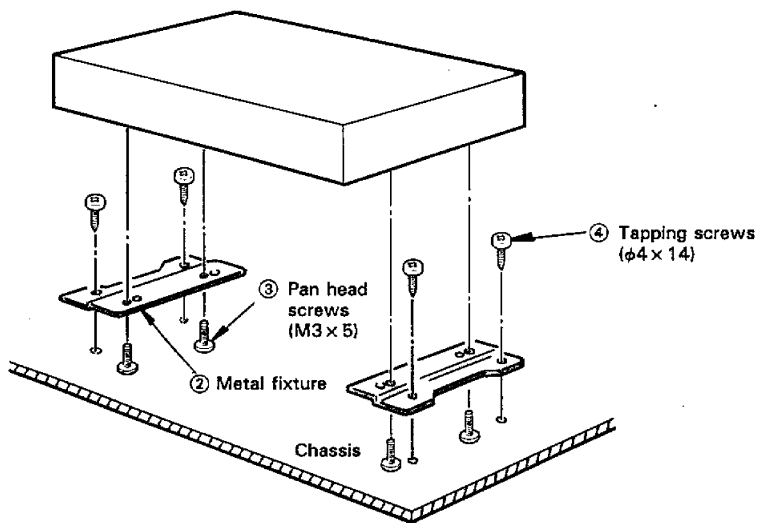

- An example of an installation position is inside a trunk room.

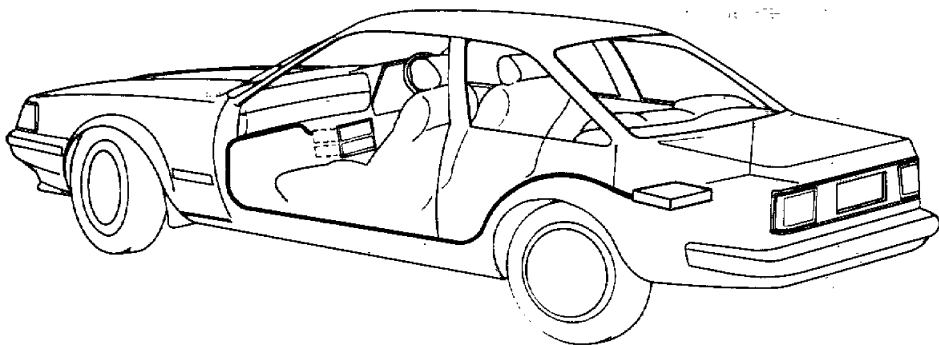

- Use the extension cables. CA-5W (0.5 m), CA-15W (1 m), CA-25W (2 m), CA-45W (4 m) and CA-65W (6 m) (optional) when the connected models are to be installed away from the electronic crossover network.

# CONNECTIONS

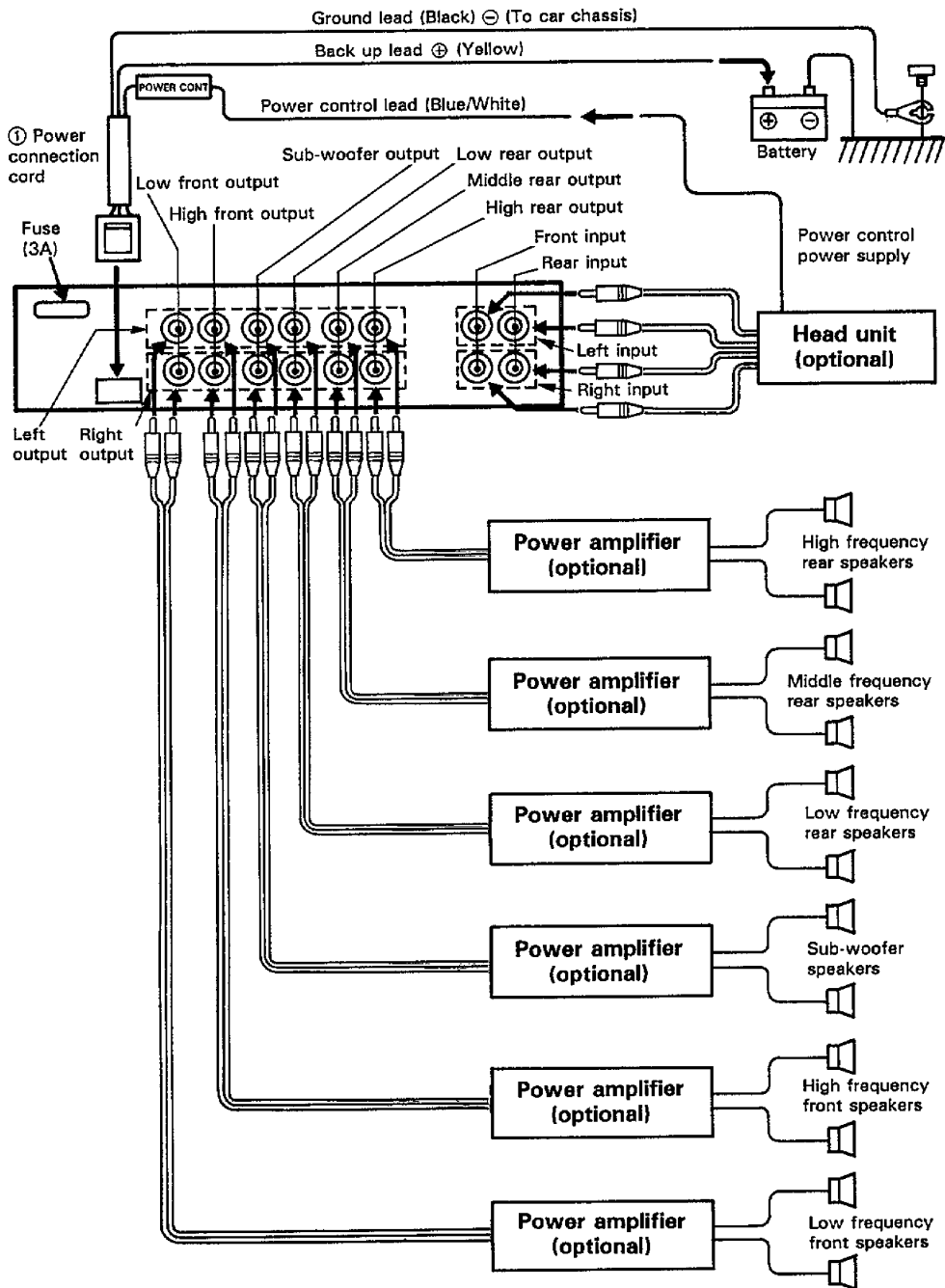



## ■ How to use the ground screws

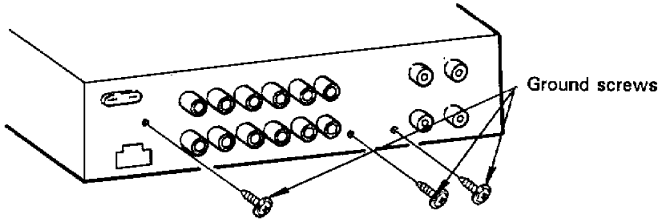

### • Use example 1

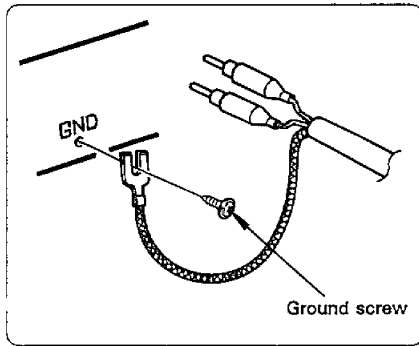

### • Use example 2

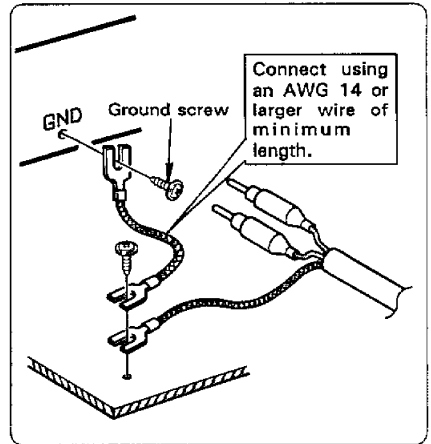

## ■ Power amplifier power control connection method

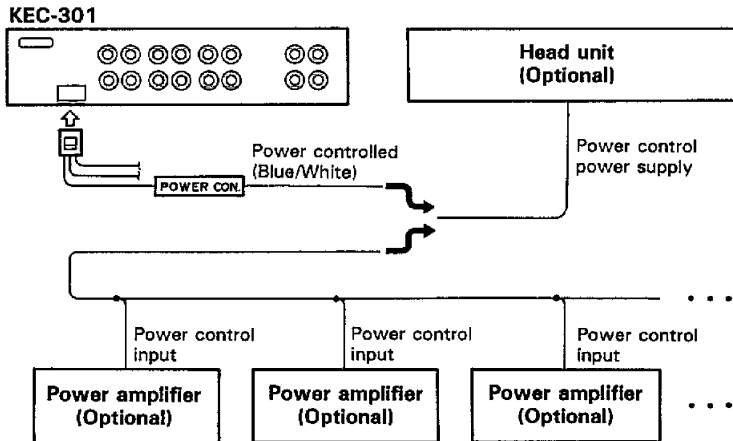

# SPECIFICATIONS

Specification subject to change without notice.

## Crossover Section

Crossover Frequency (variable)

Front (Low) .....	800 ~ 10 kHz
(High) .....	800 ~ 10 kHz
Rear (Sub-woofer) .....	30 ~ 150 Hz
(Low) .....	30 ~ 800 Hz
(Middle 1) .....	30 ~ 800 Hz
(Middle 2) .....	800 ~ 10 kHz
(High) .....	800 ~ 10 kHz

Level Control

Front (Low, High) .....	-∞ ~ 0 dB
Rear (Sub-woofer) .....	-∞ ~ +10 dB
(Low) .....	-∞ ~ 0 dB
(Middle 1, Middle 2) .....	-∞ ~ 0 dB
(High) .....	-∞ ~ 0 dB

Lowcut Frequency (selectable)

Front .....	Through, 80 Hz, 120 Hz
Rear .....	Through, 50 Hz, 80 Hz, 120 Hz

Crossover Slope.....12 dB/oct.

Sub-woofer Crossover slope

Stereo .....	12 dB/oct.
Monaural .....	18 dB/oct.

## Audio Section

Input Impedance .....	10 k $\Omega$
Output Impedance .....	600 $\Omega$
Signal to Noise Ratio .....	100 dB
T.H.D. ....	0.01 %
Frequency Response .....	20 ~ 100 kHz (-3 dB)

## General

Operating Voltage .....	14.4 V (11 ~ 16 V)
Current Consumption (MAX.) .....	0.3 A
Dimensions (W x H x D) .....	250 x 45 x 150 mm (9-13/16 x 1-3/4 x 5-7/8 in.)
Weight .....	1.4 kg (3.1 lb)